



ASME B18.2.3.9M Flange Bolt

Leader-Fastener is a manufacturer and distributor of **ASME B18.2.3.9M Flange Bolt**.

We have a complete line of service from having invested in production plants, export department and to having a quality control team and center to meet your requirements. We regard quality as the life of the company. We persist in good quality as the first policy and have established a set of quality control and inspection system according to the international standard. We have carried out ISO9001 Quality Guarantee System in every course of production, transportation and selling. We do hope we could be your partner in business by topping quality, knight service

and competitive price in the near future and be your friends as well.

The **ASME B18.2.3.9M Flange Bolt** is an integral bolt composed of a hexagon head and a flange plate (the gasket under the hexagon is fixed with the hexagon) and a screw (a cylinder with an external thread). It needs to be matched with a nut for fastening. Parts connecting two through holes, so the bolt connection is a detachable connection. Flange bolts are composed of hexagonal heads and flanges. The "ratio of support area to stress area" is larger than that of ordinary bolts, so this kind of bolts can withstand higher preloading force and have better anti-loosening performance, so they are widely used. Used in automotive engines, heavy machinery and other products. According to the force mode of the connection, there are ordinary ones and those with reaming holes. The flange bolts used for reaming holes should be matched with the size of the holes and are used when they are subjected to lateral force. In addition, in order to meet the needs of locking after installation, there are rods with holes, these holes can prevent the bolts from loosening when they are subjected to vibration. Some flange bolts have no thread for smooth rod parts, which are called thin rod flange bolts. This kind of flange bolt is conducive to the connection under variable force.

ASME B 18.2.3.9M - 2001 (R2014) Metric Heavy Hex Head Flange Screws (SAE J1199 / ASTM F568M, F738M, F468M, 8.8, 9.8, 10.9)

Type S:

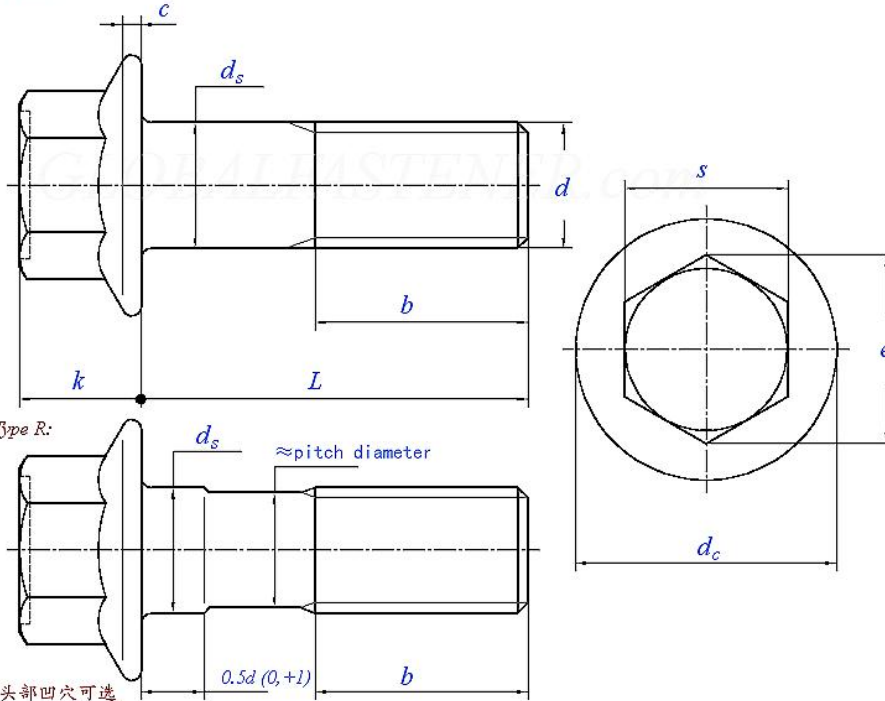

头部凹穴可选

Thread Size		M5	M6	M8	M10	M12	M14	M16	M20
d									
P	Pitch	0.8	1	1.25	1.5	1.75	2	2	2.5
d _s	max	5	6	8	10	12	14	16	20
	min	4.82	5.82	7.78	9.78	11.73	13.73	15.73	19.67
s	max	8	10	13	15	18	21	24	30
	min	7.64	9.64	12.57	14.57	17.57	20.16	23.16	29.16
e	max	9.24	11.55	15.01	17.32	20.78	24.25	27.71	34.64
	min	8.56	10.8	14.08	16.32	19.68	22.58	25.94	32.66
d _c	max	11.8	14.2	18	22.3	26.6	30.5	35	43
c	min	1	1.1	1.2	1.5	1.8	2.1	2.4	3
k	max	5.8	6.6	8.1	10.4	11.8	13.7	15.4	18.9
b	L ≤ 125	16	18	22	26	30	34	38	46
	125 < L ≤ 200	22	24	28	32	36	40	44	52
	L > 200	35	37	41	45	49	53	57	65
Length of Thread b		-	-	-	-	-	-	-	-